

been determined by the dynamic isoteniscope method.

2. Dissociation of the dihydrochloride is complete at 197.8° under one atmosphere pressure.

3. The dihydrobromide undergoes decomposition at temperatures below its melting point and satisfactory dissociation pressures are obtainable only at lower temperatures.

CORVALLIS, OREGON

RECEIVED NOVEMBER 27, 1933

[CONTRIBUTION FROM THE MALLINCKRODT CHEMICAL LABORATORY OF HARVARD UNIVERSITY]

The Thermal Decomposition of Tertiary Butyl and Tertiary Amyl Alcohols. Homogeneous Unimolecular Reactions

BY RAYMOND F. SCHULTZ AND G. B. KISTIAKOWSKY

The work described below, on the decomposition of tertiary butyl and tertiary amyl alcohols, was undertaken in an attempt to find more homogeneous unimolecular reactions which do not involve a complete rupture of the molecule; here instead merely the breaking of two bonds (one a C—H the other a C—O) with the formation of water is involved. The main reactions occurring can be written schematically as follows.

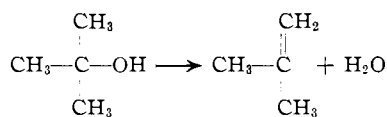

and

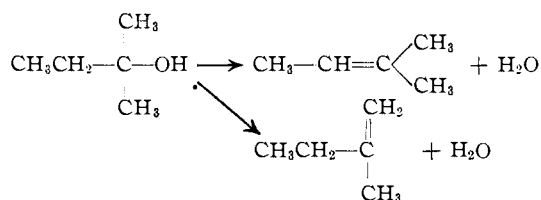

The only previous work on these has been done with catalysts like Al_2O_3 and various metals. The decomposition of tertiary butyl alcohol into water and isobutylene has been reported in the presence of graphite at 480–500°,¹ copper at 280–400°,² AlPO_4 at 200°,³ and bauxite at about 100°.⁴ The formation of the theoretical quantity of water has been observed when the alcohol is heated in a steel bomb for two hours at about 400–500°.⁵ The work of Dohse⁴ on the catalytic dehydration over bauxite is a detailed kinetic study from which he calculated an activation energy of 20,000 cal. for a first order reaction. He used a flow method with continuous removal of

water by barium oxide to prevent saturation of the catalyst.

The decomposition of tertiary amyl alcohol into trimethylethylene, methylethylene or a mixture of both and water has also been observed under a variety of conditions. This reaction has been studied by passing the alcohol vapor through an iron tube at 660–700° and 750–800°,⁶ over Al_2O_3 at 380°,⁷ over AlPO_4 at 300–350°,³ by flow method over iron or static in iron bomb at 600–610°,⁸ at 260, 400 and 540° over Al_2O_3 ,⁹ at 300° over copper and at 220–230° over nickel,² and at 45–75° over Al_2O_3 .¹⁰ The last work was a thorough kinetic study which yielded an activation energy of 17,500 cal. Those reactions taking place at 500° and higher were undoubtedly to some extent homogeneous, since, as will be shown below, the homogeneous reaction is quite fast in this temperature range.

For our investigation a static method was used and the temperature range covered was 487–555°.

Experimental Procedure

Purification of Compounds.—The starting point was a commercial "absolute" tertiary butyl alcohol known to have originated from cracked petroleum hydrocarbons. Thus it was certain to be contaminated with other adjacent secondary and tertiary alcohols. Fractional distillation was used to remove all the alcohols except isopropyl, which boils within 0.5° of tertiary butyl alcohol. Isopropyl alcohol was removed by fractional crystallization since tertiary butyl freezes at 25° and isopropyl at –85°. When the freezing point of the mixture became constant it was again fractionally distilled to remove most of the water picked up in the freezing out process. This was followed by distillation over 2% of its weight of metallic sodium to remove the last traces of water. The material

(1) Ipatiew, *Ber.*, **35**, 1064 (1902).

(2) Sabatier and Senderens, *Compt. rend.*, **136**, 986 (1903).

(3) Senderens, *ibid.*, **144**, 1110.

(4) Dohse, *Z. physik. Chem.*, **B6**, 343 (1929).

(5) Herndon and Reid, *THIS JOURNAL*, **50**, 3066 (1928).

(6) Ipatiew, *Ber.*, **34**, 600 (1901).

(7) Ipatiew, *ibid.*, **36**, 2002 (1903).

(8) Ipatiew, *ibid.*, **37**, 2980 (1904).

(9) Ipatiew, *ibid.*, **37**, 3001 (1904).

(10) Dohse, *Z. physik. Chem.*, Bodenstein Festband 533 (1931).

so obtained boiled within a 0.5° range and froze at 24° . Finally the material was vacuum distilled into a storage flask to remove dissolved gases.

The purification of the tertiary amyl alcohol, originating from the same source as the tertiary butyl, did not necessi-

that remaining in C. The initial pressure measurement was made using a "clicker" gage E as a null point instrument. Using this sample measuring system it was possible to measure and duplicate initial pressures quite accurately even at very high reaction speeds.

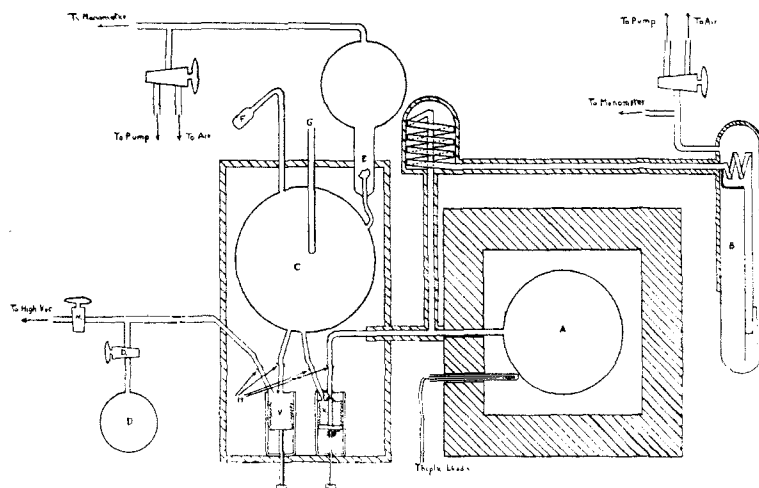

Fig. 1.—Diagram of apparatus.

tate a fractional crystallization. It was first fractionated. The material collected boiled at $101\text{--}103^\circ$. This fraction was refluxed over lime for about eight hours and then distilled. Another fractionation resulted in a fraction boiling from 101.7 to 102.3° . This material was distilled off from 2% of its weight of metallic sodium and finally vacuum distilled into another storage flask.

The apparatus in its final form is illustrated in Fig. 1. It consists essentially of a quartz reaction flask, surrounded by a suitable manually controlled furnace, a mercury manometer separated from the reaction flask by a quartz spiral null point instrument, and a sample measuring system. The construction of the latter is evident from the diagram and its operation is best seen in a description of the procedure for a typical run. The entire sample measuring system when used with tertiary butyl alcohol was kept at a temperature of about 80° with a specially made heating unit to prevent condensation of the alcohol in the apparatus. With tertiary amyl the temperature was raised to about 90° . The temperature inside Flask C was measured with a thermometer inserted in a well G and surrounded by mercury. The vacuum was obtained with a two-stage diffusion pump backed by a mechanical pump. After evacuating the entire system the sample used in making a typical run was condensed in F while valve V, and stopcock H, were closed. Closure of valve V and subsequent evaporation of sample into C enabled one to measure the relative amount present. If the sample was sufficient, the opening of valve V, for a second or two with simultaneous recording of time, started the run. When enough measurements had been made, the initial pressure was taken as

Results and Interpretation.—

Analysis of typical reaction mixtures of tertiary butyl alcohol and its decomposition products justified the assumption that one mole of the alcohol produced one mole of water and one mole of isobutylene. The analysis consisted of measuring the refractive index of the portion remaining liquid at room temperature. Since isobutylene boils at -8° , this procedure worked fairly well when the concentration of the latter was low. A typical run gave 19.5% decomposition by analysis and 20.8% by calculation from the pressure change. The

runs with tertiary amyl alcohol were calculated in the same manner although the analysis of reaction mixtures was not so successful due to the high boiling point of the alkylene formed.

The unimolecular rate constants and experi-

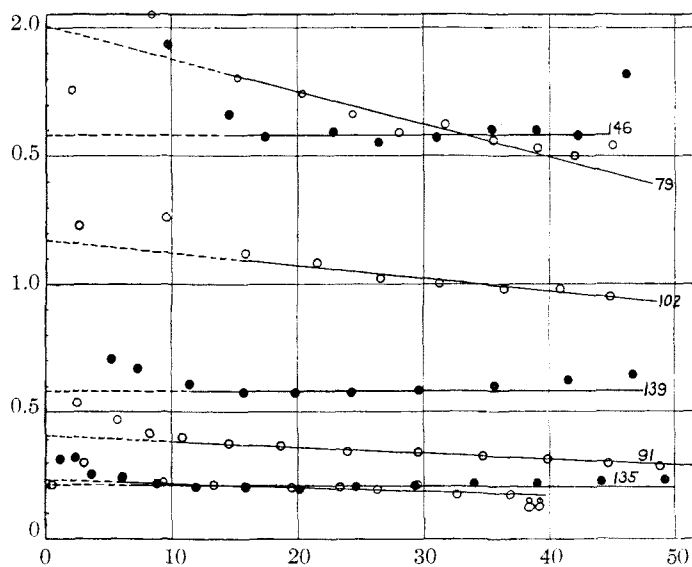

Fig. 2.—Plot of % decomposition against K . Circles for t -butyl alcohol and solid circles for t -amyl alcohol. Numbers refer to Tables I and II.

mental data for both of the alcohols are summarized in Tables I and II; the column headings are self-explanatory. In Fig. 2 are shown plots of typical data and extrapolations at various

temperatures. The constant reported for each run was obtained by plotting the constant obtained for each interval against the percentage decomposed and then extrapolating to zero per cent. decomposition. This was necessary as a slight falling off of the constant during the course of a run was always observed. The slow rise of the rate constant after about 50% of the material had decomposed is believed to be due to a secondary decomposition of the alkylene formed in the reaction. The reaction was homogeneous within experimental error. The run numbers with the subscript "p" had approximately four times as much surface as the other runs. At the highest temperatures used with tertiary butyl alcohol, the addition of a little water (indicated in parentheses) at the start of the run avoided an initial very high constant with a following rapid drop. This is probably due to the effect of water in retarding the heterogeneous part of the reaction at the beginning of a run. An-

other precaution we found necessary in the efforts to obtain homogeneity was the practice of "poisoning" a clean reaction flask by letting a high pressure of alcohol react and remain in contact with the flask for about twelve hours. When

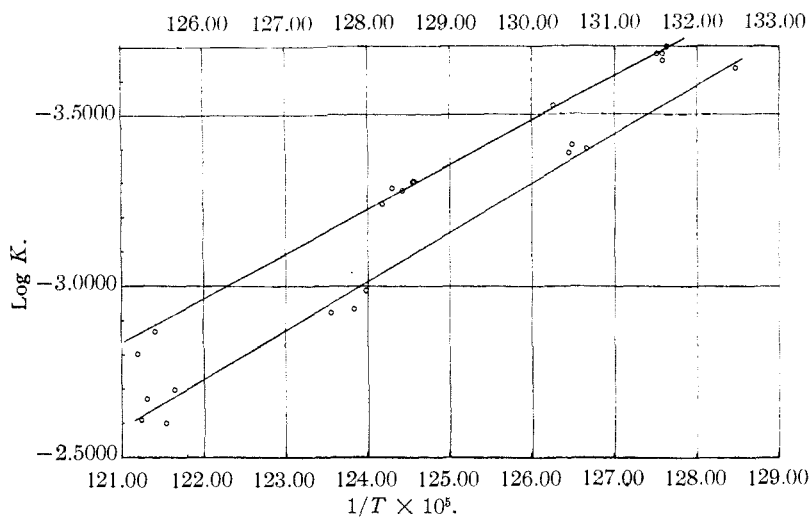

Fig. 3.—Plot of log *K* against 1/*T*: upper curve for *t*-amyl alcohol; lower curve for *t*-butyl alcohol.

this was not done the constants were high and irreproducible.

The usual plots of log *k* against 1/*T*, as illustrated in Fig. 3, result in straight lines having slopes corresponding to activation energies of 65,500 calories and 60,000 calories for tertiary butyl and tertiary amyl alcohols, respectively. The error in the activation energy of the tertiary butyl alcohol decomposition seems greater than that for tertiary amyl alcohol and is about 5000

TABLE I
DECOMPOSITION OF *t*-BUTYL ALCOHOL

Run	<i>T</i> , °C.	<i>P</i> ₀	<i>k</i> × 10 ³ , sec. ⁻¹
78	551.2	323.3 (+28.8 <i>m</i> H ₂ O)	2.15
79	549.0	325.4 (+55.5 <i>m</i> H ₂ O)	2.01
80	549.7	278.5 (+109 <i>m</i> H ₂ O)	2.52
81	553.7	128.3 (+54.9 <i>m</i> H ₂ O)	2.46
82	554.4	198.4 (+51.9 <i>m</i> H ₂ O)	2.30
102	534.4	339.7	1.17
104	536.2	181.8	1.20
105	533.5	104.4	1.03
107	534.7	47.0	0.99
106	536.3	26.3	1.12
103	535.6	11.9	0.99
89	517.5	344.2	.39
90	517.8	342.8	.41
91	516.4	200.3	.40
92	515.6	79.2	.35
93	516.1	57.9	.36
97	514.3	46.7	.35
98	515.5	23.2	.37
99	515.0	13.7	.34
115 <i>p</i>	515.2	14.9	.37
117 <i>p</i>	513.8	4.94	.37
118 <i>p</i>	515.2	2.95	.37
119 <i>p</i>	515.9	1.66	.24
88	505.3	259.4	.23

TABLE II
DECOMPOSITION OF *t*-AMYL ALCOHOL

Run	<i>T</i> , °C.	<i>P</i> ₀	<i>k</i> × 10 ³ sec. ⁻¹
145	524.3	324.0	1.36
146	525.7	318.0	1.58
141	504.9	304.0	0.50
125 <i>p</i>	505.6	252.0	.53
139	507.0	188.0	.53
144	506.3	89.8	.52
140	504.9	45.0	.50
131 <i>p</i>	507.2	24.6	.55
126 <i>p</i>	494.6	313.0	.30
129 <i>p</i>	486.6	267.0	.20
133	486.9	268.0	.22
135	486.9	290.0	.21
136	487.3	170.5	.21
137	485.7	88.0	.19
138	484.3	34.4	.16
134	487.5	19.4	.24
130 <i>p</i>	487.8	21.4	.18

calories. Thus their activation energies are very nearly equal with the tertiary amyl slightly lower. This decrease of the activation energy with increasing complexity of the molecule in a given homologous series has been occasionally observed before. The value of the constant when expressed as $k = Ae^{-E/RT}$ necessitates that A be equal to 4.8×10^{14} for tertiary butyl alcohol and 3.3×10^{13} for the tertiary amyl homolog.

When the values of k for tertiary butyl alcohol at or near 516° are corrected to 516° , as shown in Table III, it seems probable that the rate has begun to fall off at or near 3 mm. initial pressure.

TABLE III
PRESSURE DEPENDENCE OF RATE CONSTANTS FOR *t*-BUTYL ALCOHOL

$T, ^\circ\text{C.}$	P_0	$k \times 10^3 \text{ sec.}^{-1}$	$k_{516^\circ} \times 10^3 \text{ sec.}^{-1}$
517.5	344.2	0.39	0.35
517.8	342.8	.41	.37
516.4	200.3	.40	.39
515.6	79.2	.35	.36
516.1	57.9	.36	.36
514.3	46.7	.35	.39
515.5	23.2	.37	.38
515.0	13.7	.34	.36
515.2	14.9	.34	.36
513.8	4.94	.35	.40
515.2	2.95	.35	.36
515.9	1.66	.28	.28

The actual amount of the fall, when obtained by the ratio of 0.28×10^{-3} to 0.37×10^{-3} (the average of all the runs above 2 mm. pressure), is probably too large. Therefore, to determine the least number of classical oscillators, participating in the activation rate, we assumed that the rate had just begun to drop at 3 mm. pressure

(10%). With this assumption and the method described by Kassel¹¹ it is found that at least 19 oscillators are necessary to maintain the activation rate. This is quite large when compared with the value of 6 oscillators in the decomposition of diethyl ether, which is the empirical isomer of tertiary butyl alcohol. Presumably the highly branched structure of the alcohol permits of more efficient energy transfer within the molecule.

The rate constants for the tertiary amyl alcohol decomposition were not reproducible at the lowest pressures and they are not included in this paper. Thus it is not possible to compute the number of squared terms participating in this reaction under conditions comparable to those obtained for tertiary butyl alcohol.

Summary

The thermal decompositions of tertiary butyl and tertiary amyl alcohols have been investigated in the temperature region of 487 – 555° .

The reactions are homogeneous, unimolecular and have activation energies of 65,500 and 60,000 calories, respectively.

The rate expressions are $k = 4.8 \times 10^{14} e^{-65,500/RT}$ for tertiary butyl alcohol and $k = 3.3 \times 10^{13} e^{-60,000/RT}$ for tertiary amyl alcohol.

In the case of tertiary butyl alcohol the rate constant begins to fall off at about 2 mm. pressure (516°), which corresponds to the participation of 19 classical oscillators in the activation process.

CAMBRIDGE, MASS.

RECEIVED DECEMBER 6, 1933

(11) L. S. Kassel, "Kinetics of Homogeneous Gas Reactions," The Chemical Catalog Co., Inc., New York, p. 210.